

PLURIGIL

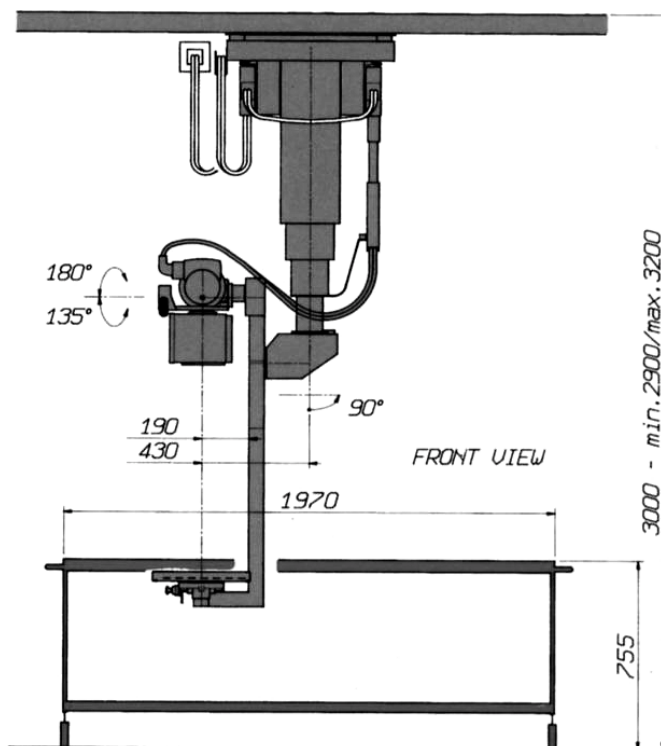

CHARACTERISTICS

Longitudinal rails and transversal bridge are made of extruded aluminium section. The telescopic elements of the stand are made of extruded aluminium. Vertical movement perfectly balancing. On the "C arm", the X-ray source is opposite to the fixed focal distance of the cassette holder with incorporated fix grid. The horizontal arm can rotate around the vertical and horizontal axis. X-ray source can be rotated. For the linear movements electromagnetic brakes are used. For the rotation movements brakes at permanent magnet are used. The cassette holder can rotate and be inclined with respect to the radiant beam axis. The cassette holder is easily and quickly replaceable with another of different size. The control box, allows to concentrate in little space all the controls for the complete management of the stand movements.



TECHNICAL SPECIFICATIONS

Longitudinal rails:	
Length/Travel of transversal bridge on the longitudinal rails	440/350cm
Transversal bridge:	
Rail length/Carriage travel on transversal bridge	300/218cm
Telescopic stand:	
Vertical travel	150cm
Angle of rotation around the telescope vertical axis	+200°÷-135°
"C arm" angle of rotation around the horizontal axis	+120°÷-120°
Angle of rotation around the horizontal axis X-ray tubehead	+180°÷-135°
Focus/film distance	125cm
angle of rotation cassette holder	0°/15°/30°
Grid (standard supply)	FD=115cm R=10:1 60L/cm
Power supply Line voltage / frequency	230 (220/240) Vac 50/60 Hz
Max. absorbed power	350 VA
Weights	325kg
Options	
cassette holder with incorporated fix grid	24x30 cm
cassette holder with incorporated fix grid	35x43 cm
Device for the automatic collimation	
"Solid state" automatic exposure chamber	
Accessories	
Stretcher with table top translucent	XL
Elavating stretcher with table top translucent	XL/E

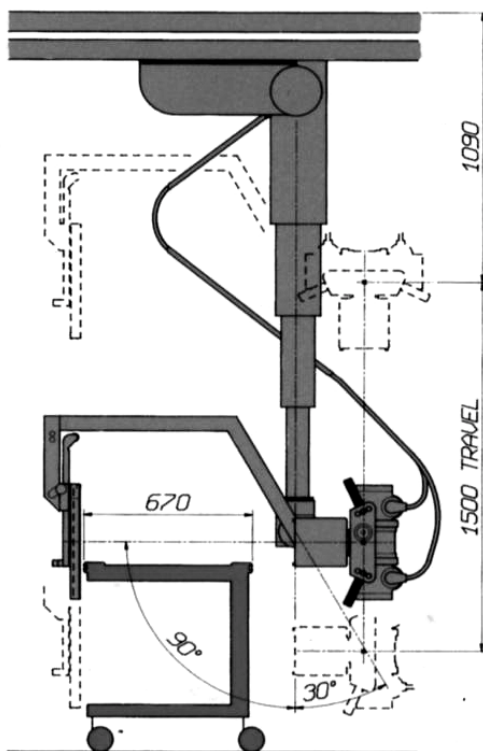

Reserving the right to improve and modify

Acknowledged as "HIGHLY QUALIFIED LABORATORY" with decree D.M. 9-10-1985 - L.46/82 art.4

Head office and facilities:

Via **Arturo Gilardoni**, 1 - 23826 Mandello del Lario (LC) - Italy
tel. (+39) 0341.705.111 - fax (+39) 0341.735.046
e-mail: gx@gilardoni.it - www.gilardoni.it

Export department:

tel. (+39) 0341.705.225 - 0341.705.241

